

Part number

CMI 16 LS



Bulkhead mounting housing, 830V series, with 1 lever, size "104.27", with metal cover

Product description		Material properties	
Product type	Bulkhead mounting housing	Colour	RAL 7040 grey
Series	830V	RoHs conformity	Compliant
Closing type	With 1 lever	China RoHs - EFUP	E
Size	Size 104.27	REACH SVHC substances	No
Cable entry	Without cable entry	Approvals / Standards	
Specification	With metal cover	Certifications	DNV, BV
Technical data		UL	ECBT2
IP degree of protection	IP65	cUL	ECBT8
Further technical details		General ordering information	
Weight	220,50 g	EAN13 code	8015747030847
Operating temperature range (min, max)	-40°C...+125°C	Packaging Information	
		Packaging length	475,00 mm
		Packaging height	220,00 mm
		Packaging width	200,00 mm
		Packaging weight	4,96 kg
		Packaging volume	20,90 dm ³
		Packaging description	Carton box
		Packaging quantity	20 Pcs
		Packaging EAN code	8015747234207
		Sub-packaging weight	1,24 kg
		Sub-packaging description	Plastic packaging
		Sub-packaging quantity	5 Pcs
		Sub-packaging EAN barcode	8015747030854

Part number

CMI 16 LS



Catalogue drawings

CMI L

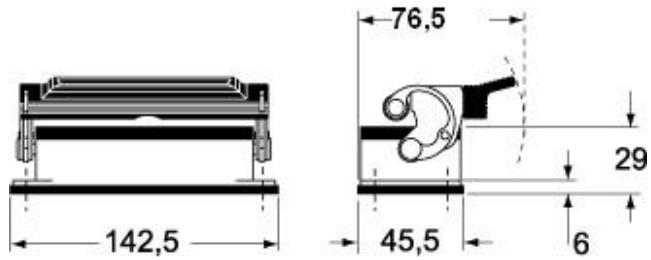

CMI LS

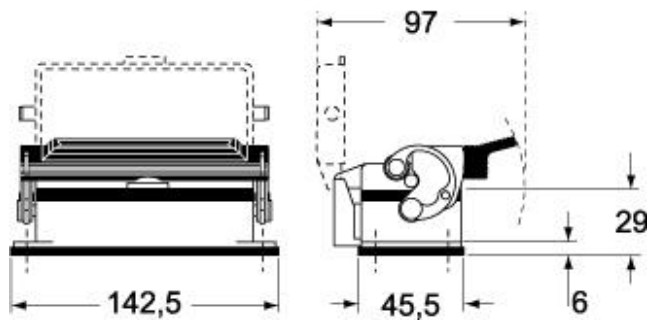

Catalogue drawings

