

Part number

# CQEYM 10



Male insert, CQEY series, AXYR® spring push-in terminal connection without tools, 10 poles + PE, 16 A 500 V 6 kV 3, size "44.27"

Product description	
<b>Product type</b>	Insert
<b>Series</b>	CQEY
<b>Connection type</b>	AXYR® high density spring terminal connection without tools
<b>Gender</b>	Male
<b>N. of poles</b>	10 poles + 
<b>Size</b>	Size 44.27
Technical data	
<b>Current</b>	16 A
<b>Voltage</b>	500 V
<b>Rated impulse withstand voltage</b>	6 kV
<b>Pollution degree</b>	3
<b>Rated voltage according to UL/CSA</b>	600 V
<b>Contact type</b>	Turned silver plated
<b>IP degree of protection</b>	IP20 without enclosure, IP44/IP66/IP67/IP68/IP69 with enclosure
Further technical details	
<b>Characteristics according to EN 61984</b>	16 A 500 V 6 kV 3
<b>Mating cycles</b>	≥ 500
<b>Insulation resistance</b>	≥ 10 GΩ
<b>Contact resistance</b>	≤ 3 mΩ
<b>Weight</b>	56,50 g
<b>Operating temperature range (min, max)</b>	-40 °C ... +125 °C
<b>Conductors stripping length</b>	9...11 mm
<b>UL 94 flammability rating</b>	V-0

Material properties	
<b>Main material</b>	Polycarbonate (PC)
<b>Other materials</b>	Contacts: copper alloy
<b>Colour</b>	RAL 7032 grey
<b>RoHs conformity</b>	Compliant with exemption 6(c): copper alloy containing up to 4% lead by weight
<b>China RoHs - EFUP</b>	50
<b>REACH SVHC substances</b>	Yes Lead
General ordering information	
<b>EAN13 code</b>	8015747292993
<b>eCl@ss 8.1</b>	27440205
<b>ETIM 7.0</b>	EC000438
Packaging Information	
<b>Packaging length</b>	245,00 mm
<b>Packaging height</b>	165,00 mm
<b>Packaging width</b>	215,00 mm
<b>Packaging weight</b>	3,67 kg
<b>Packaging volume</b>	8,69 dm <sup>3</sup>
<b>Packaging description</b>	Carton box
<b>Packaging quantity</b>	60 Pcs
<b>Packaging EAN code</b>	8015747293006
<b>Sub-packaging weight</b>	0,06 kg
<b>Sub-packaging description</b>	Plastic bag
<b>Sub-packaging quantity</b>	1 Pcs
<b>Sub-packaging EAN barcode</b>	8015747293693

Part number

# CQEYM 10



## Catalogue drawings

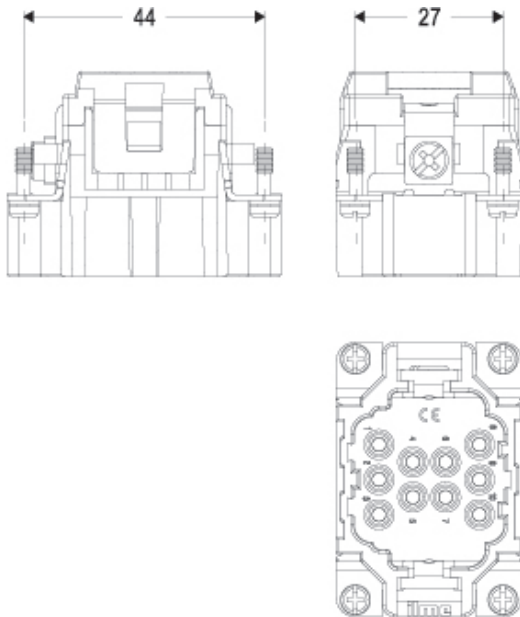

## Derating curves

**CQEY 10 poles connector inserts**  
**Maximum current load derating diagram**

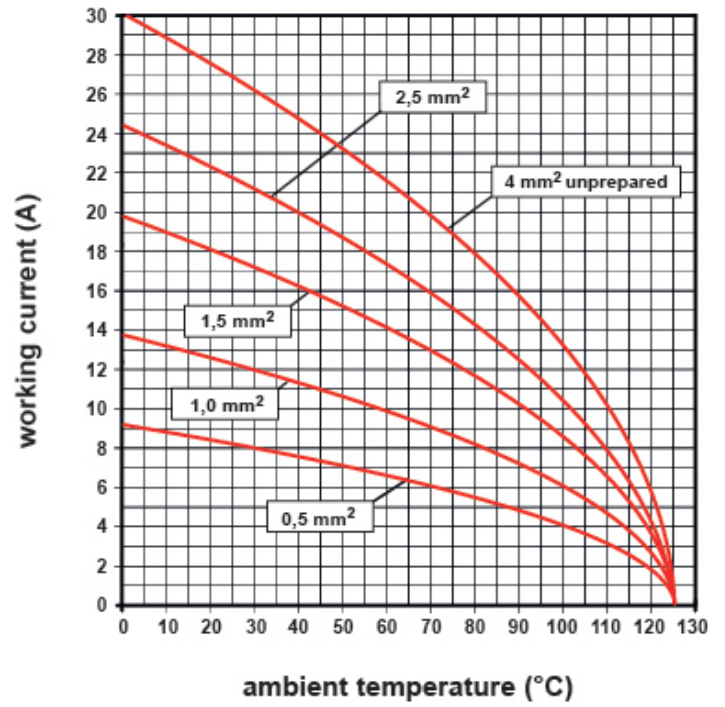

Notes