

Part number

CMI 16



Bulkhead mounting housing, 830V series, with 2 levers, size "104.27"

Product description

Product type	Bulkhead mounting housing
Series	830V
Closing type	With 2 levers
Size	Size 104.27
Cable entry	Without cable entry

Technical data

IP degree of protection	IP65 / IP66 / IP69
--------------------------------	--------------------

Further technical details

Weight	180,00 g
Operating temperature range (min, max)	-40°C...+125°C

Material properties

Colour	RAL 7040 grey
RoHs conformity	Compliant
China RoHs - EFUP	E
REACH SVHC substances	No

Approvals / Standards

Certifications	DNV, BV
UL	ECBT2
cUL	ECBT8

General ordering information

EAN13 code	8015747030700
-------------------	---------------

Packaging Information

Packaging length	180,00 mm
Packaging height	210,00 mm
Packaging width	330,00 mm
Packaging weight	3,62 kg
Packaging volume	12,47 dm ³
Packaging description	Carton box
Packaging quantity	20 Pcs
Packaging EAN code	8015747234184
Sub-packaging weight	0,91 kg
Sub-packaging description	Plastic packaging
Sub-packaging quantity	5 Pcs
Sub-packaging EAN barcode	8015747030717

Part number

CMI 16



Catalogue drawings

CMI

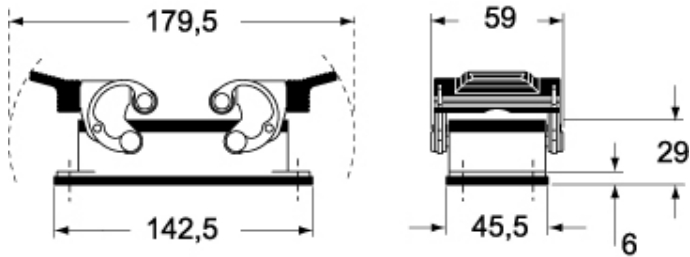

CMI CS/CP

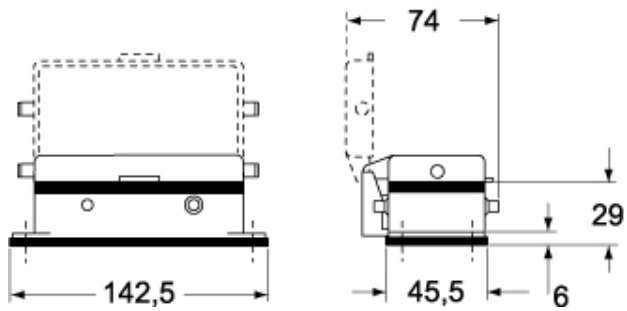

Catalogue drawings

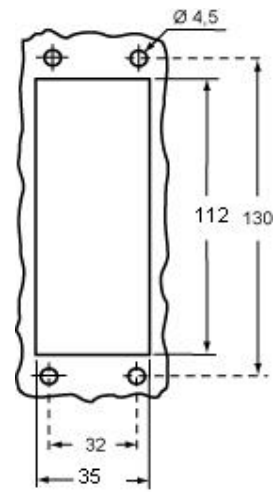

Notes