

Part number

# CKH 03 I



Bulkhead mounting housing, CKH series, with 1 lever, size "21.21"

#### Product description

<b>Product type</b>	Bulkhead mounting housing
<b>Series</b>	CKH
<b>Closing type</b>	With 1 lever
<b>Size</b>	Size "21.21"
<b>Cable entry</b>	Without cable entry

#### Technical data

<b>IP degree of protection</b>	IP44 (IP66/IP67/IP69 with CKRH 65/CKRH 65 D kits)
--------------------------------	---

#### Further technical details

<b>Weight</b>	9,00 g
<b>Operating temperature range (min, max)</b>	-40°C...+70°C

#### Material properties

<b>Main material</b>	Polyamide (PA)
<b>Other materials</b>	Lever: Polypropylene (PP), metal-detectable Gasket: Silicone rubber
<b>Colour</b>	RAL 7012 grey, RAL 5005 blue

#### General ordering information

<b>EAN13 code</b>	8015747272001
<b>eCl@ss 8.1</b>	27440202
<b>ETIM 7.0</b>	EC000437

#### Packaging Information

<b>Sub-packaging description</b>	Plastic bag
<b>Sub-packaging quantity</b>	1 Pcs
<b>Sub-packaging EAN barcode</b>	8015747280457

Part number

# CKH 03 I



Catalogue drawings

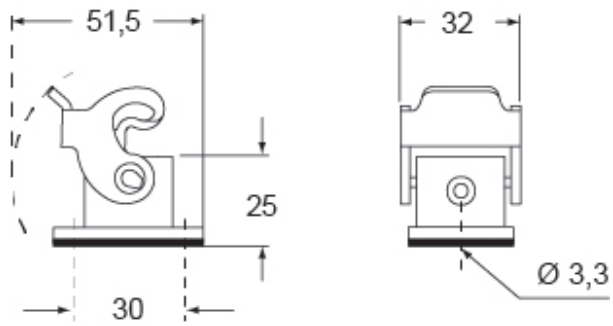

Catalogue drawings

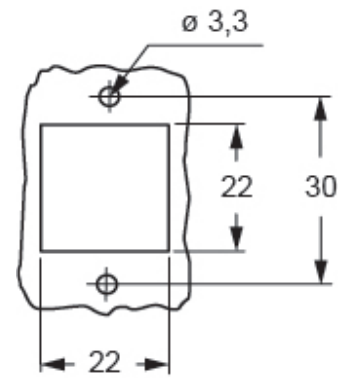

Notes