

Part number

# RKAX IAP25

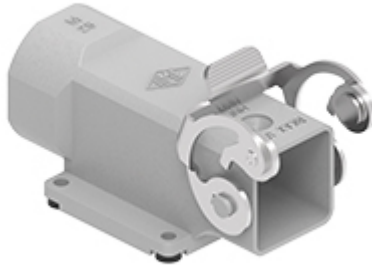

Angled Bulkhead mounting housing, CKA series, HNM - High Number of Matings series, with 1 lever, M25 cable entry, size "21.21"

#### Product description

<b>Product type</b>	Angled bulkhead mounting housing
<b>Series</b>	HNM - High Number of Matings
<b>Closing type</b>	With 1 lever
<b>Size</b>	Size "21.21"
<b>Cable entry</b>	With cable entry M25

#### Technical data

**IP degree of protection** IP44 - IP66 / IP67 / IP69 with CKR 65 (D)

#### Further technical details

<b>Weight</b>	102,00 g
<b>Operating temperature range (min, max)</b>	-40°C...+125°C

#### Material properties

<b>Main material</b>	Zinc die-cast
<b>Other materials</b>	Lever: stainless steel
<b>Colour</b>	RAL 7040 grey
<b>RoHs conformity</b>	Compliant
<b>China RoHs - EFUP</b>	E
<b>REACH SVHC substances</b>	No

#### General ordering information

<b>EAN13 code</b>	8015747140324
<b>eCl@ss 8.1</b>	27440202
<b>ETIM 7.0</b>	EC000437

#### Packaging Information

<b>Packaging weight</b>	10,72 kg
<b>Packaging description</b>	Carton box
<b>Packaging quantity</b>	100 Pcs
<b>Packaging EAN code</b>	8015747183215
<b>Sub-packaging length</b>	210,00 mm
<b>Sub-packaging height</b>	40,00 mm
<b>Sub-packaging width</b>	175,00 mm
<b>Sub-packaging weight</b>	1,07 kg
<b>Sub-packaging volume</b>	1,47 dm <sup>3</sup>
<b>Sub-packaging description</b>	Carton box
<b>Sub-packaging quantity</b>	10 Pcs
<b>Sub-packaging EAN barcode</b>	8015747183222

Part number

# RKAX IAP25



Catalogue drawings

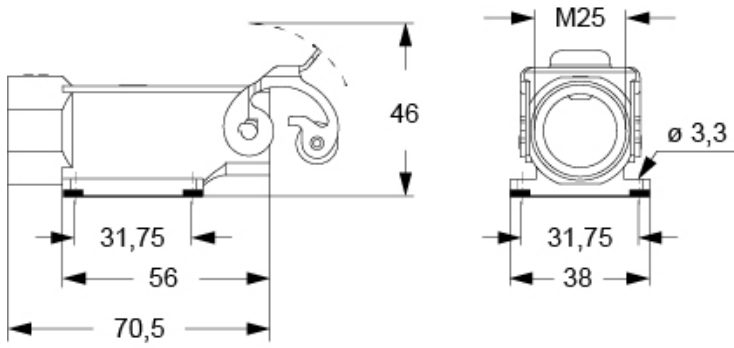

Catalogue drawings

