

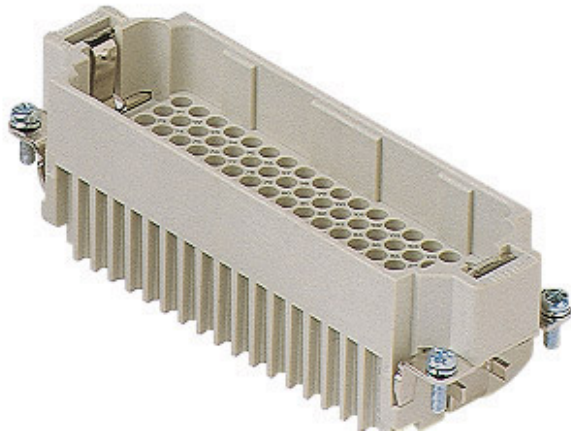

Part number

CDDM 108 N



Male insert, CDD series, crimp connection, 108 poles + PE (109-216), 10 A 250 V 4 kV 2, size "104.62"

Product description	
Product type	Insert
Series	CDD
Connection type	Crimp connection
Gender	Male
N. of poles	216 poles + 
Size	Size 104.62
Technical data	
Current	10 A
Voltage	250 V
Rated impulse withstand voltage	4 kV
Pollution degree	2
Rated voltage according to UL/CSA	600 V
Pole numbering system	109-216
IP degree of protection	IP20 without enclosure, IP65/IP66 with enclosure
Further technical details	
Characteristics according to EN 61984	10A 250V 4kV 2
Mating cycles	≥ 500
Insulation resistance	≥ 10 GΩ
Contact resistance	≤ 3 mΩ
Weight	7,50 g
Operating temperature range (min, max)	-40 °C ... +125 °C
UL 94 flammability rating	V-0
Tightening torque for PE connection	M4: 1,2 Nm, 10,6 lb.in (Ph2 or 1,0x5,5mm)
Tightening torque for fixing screws	M3: 0.5 Nm; 4.4 lb.in (Ph1 or 0.8x4 mm)

Material properties	
Main material	Polycarbonate (PC)
Colour	RAL 7032 grey
RoHs conformity	Compliant
China RoHs - EFUP	E
REACH SVHC substances	No
Approvals / Standards	
Reference standard	EN 61984:2009-06
Certifications	CSAc, CQC, DNV, BV, EAC
UL	ECBT2
cUL	ECBT8
General ordering information	
EAN13 code	8015747013956
eCl@ss 8.1	27440205
ETIM 7.0	EC000438
Packaging Information	
Packaging length	270,00 mm
Packaging height	75,00 mm
Packaging width	180,00 mm
Packaging weight	2,50 kg
Packaging volume	3,65 dm ³
Packaging description	Carton box
Packaging quantity	30 Pcs
Packaging EAN code	8015747013963
Sub-packaging length	113,00 mm
Sub-packaging height	36,00 mm
Sub-packaging width	180,00 mm
Sub-packaging weight	0,42 kg
Sub-packaging volume	0,73 dm ³
Sub-packaging description	Carton tray
Sub-packaging quantity	5 Pcs
Sub-packaging EAN barcode	8015747013970

Part number

CDDM 108 N



Catalogue drawings

Catalogue drawings

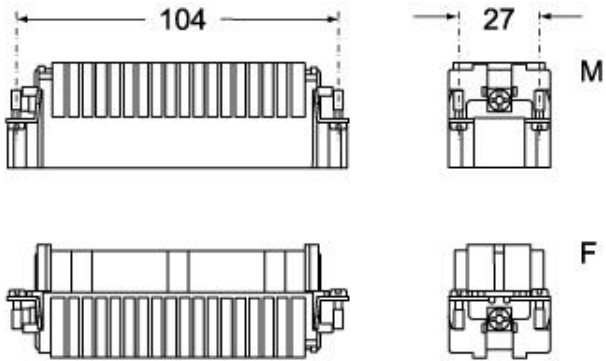

CDDF 108 N
CDDF 108

CDDM 108 N
CDDM 108

