

Part number

CKAXS 03 IAP



Angled Bulkhead mounting housing, EMC series, with 1 lever, Pg11 cable entry, size "21.21"

Product description		Material properties	
Product type	Angled bulkhead mounting housing	Main material	Zinc die-cast
Series	EMC	Other materials	Lever: Stainless steel Gasket: Conductive elastomer
Closing type	With 1 lever	Colour	RAL 7040 grey
Size	Size "21.21"	RoHs conformity	Compliant
Cable entry	With cable entry Pg11	China RoHs - EFUP	E
Technical data		REACH SVHC substances	No
IP degree of protection	IP44 - IP66 / IP67 / IP69 with CKR 65 (D)	Approvals / Standards	
Further technical details		Certifications	DNV, BV
Weight	70,60 g	UL	ECBT2
Operating temperature range (min, max)	-40°C...+125°C	cUL	ECBT8
		General ordering information	
		EAN13 code	8015747027816
		Packaging Information	
		Packaging length	450,00 mm
		Packaging height	175,00 mm
		Packaging width	230,00 mm
		Packaging weight	8,36 kg
		Packaging volume	18,11 dm ³
		Packaging description	Carton box
		Packaging quantity	100 Pcs
		Packaging EAN code	8015747234009
		Sub-packaging length	210,00 mm
		Sub-packaging height	40,00 mm
		Sub-packaging width	175,00 mm
		Sub-packaging weight	0,84 kg
		Sub-packaging volume	1,47 dm ³
		Sub-packaging description	Carton box
		Sub-packaging quantity	10 Pcs
		Sub-packaging EAN barcode	8015747234016

Part number

CKAXS 03 IAP



Catalogue drawings

CKAXS I

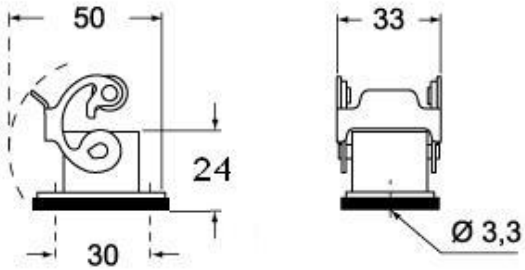

Catalogue drawings

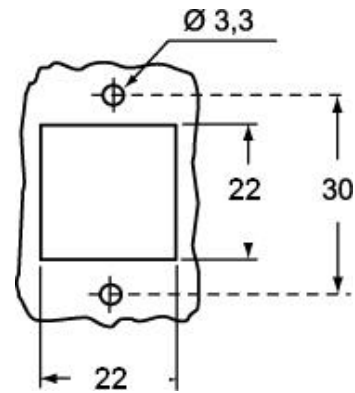

CKAXS IA

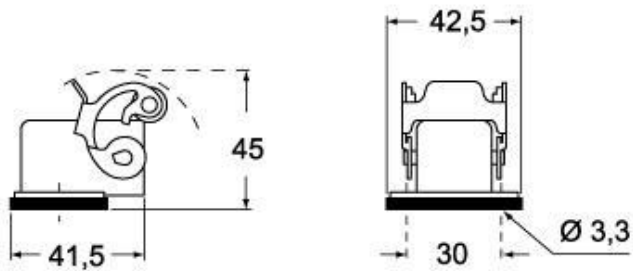

CKAXS IAP (CKAXS AP) MKAXS IAP (MKAXS AP)

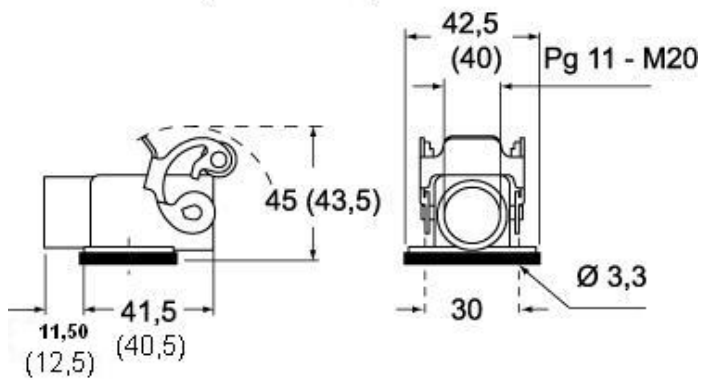

Notes